

STAR TREK™

THE OFFICIAL STARSHIPS COLLECTION



U.S.S. ENTERPRISE XCV-330
SPECIAL ISSUE

UNKNOWN CLASS

LAUNCHED: 22ND C

EARLY WARP SHIP

EARTH XCV-330 PROGRAM

Contents

04: PROFILE: *U.S.S. ENTERPRISE*

06: HISTORY OF THE RING SHIP

14: THE MOTION PICTURE'S LOST ALIENS

U.S.S. ENTERPRISE
XCV-330

Stand assembly:

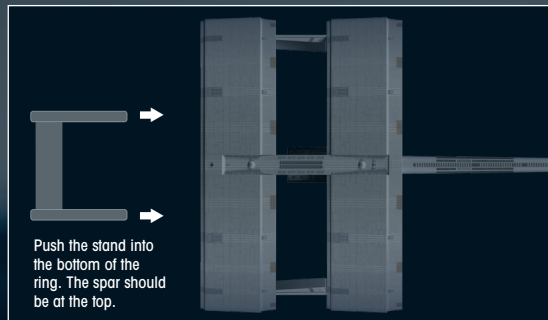

ORDER ONLINE

Order binders, missing issues or other Eaglemoss products at:

www.mycollectionshop.com

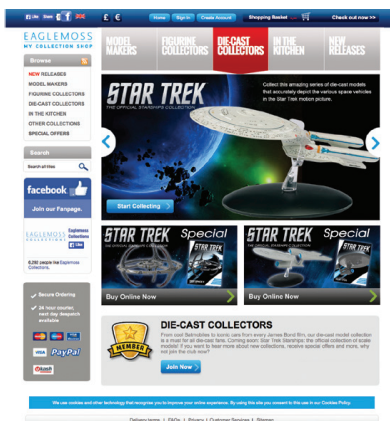

EAGLEMOSS COLLECTIONS

Eaglemoss Publications Ltd. 2017
1st Floor, Kensington Village, Avonmore Road,
W14 8TS, London, UK. All rights reserved.

™ & © 2017 CBS Studios Inc. © 2017 Paramount
Pictures Corp. STAR TREK and related marks and
logos are trademarks of CBS Studios Inc. All Rights
Reserved.

Development Director:
Maggie Calmels

STAR TREK – The Official Starships Collection is
published fortnightly.

DON'T MISS AN ISSUE: place a regular order with
your magazine retailer.

SUBSCRIBE and receive exclusive free gifts –
www.startrek-starships.com
Call 0344 493 6091
Post the subscription form included with issues 1 to 5

BACK ISSUES
To order back issues: Order online at
www.startrek-starships.com or call 0344 493 6091

UK distributor: COMAG Magazine Marketing

 **Find us on
Facebook**

Join us online for competitions, updates and more!

CUSTOMER SERVICES:
www.startrek-starships.com

UK: 0344 493 6091
startrek-ship@eaglemoss-service.com

Australia: (03) 9872 4000
bissett@bissettmags.com.au

New Zealand: (09) 308 2871
Fax: (09) 302 7661
subs@ndc.co.nz

South Africa: (011) 265 4307
service@jacklin.co.za

Malaysia: (03) 8020 7112
sales@allscript.com

Singapore: (65) 6287 7090
sales@allscript.com

OVERSEAS BACK ISSUES
Place your order with your local magazine retailer.

Recommended age 14+.
Warning! Collectable figurines.
Not designed or intended for play by children.
Do not dispose of in domestic waste.

www.startrek-starships.com

U.S.S. ENTERPRISE

SPECIFICATION



CLASS: UNKNOWN

REGISTRY: XCV-330

LAUNCHED: BEFORE 2143

SPEED: LESS THAN WARP 4

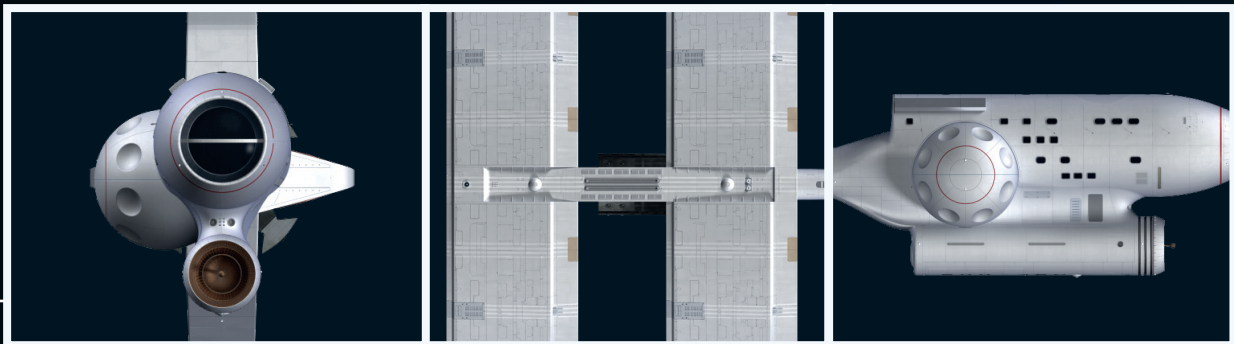

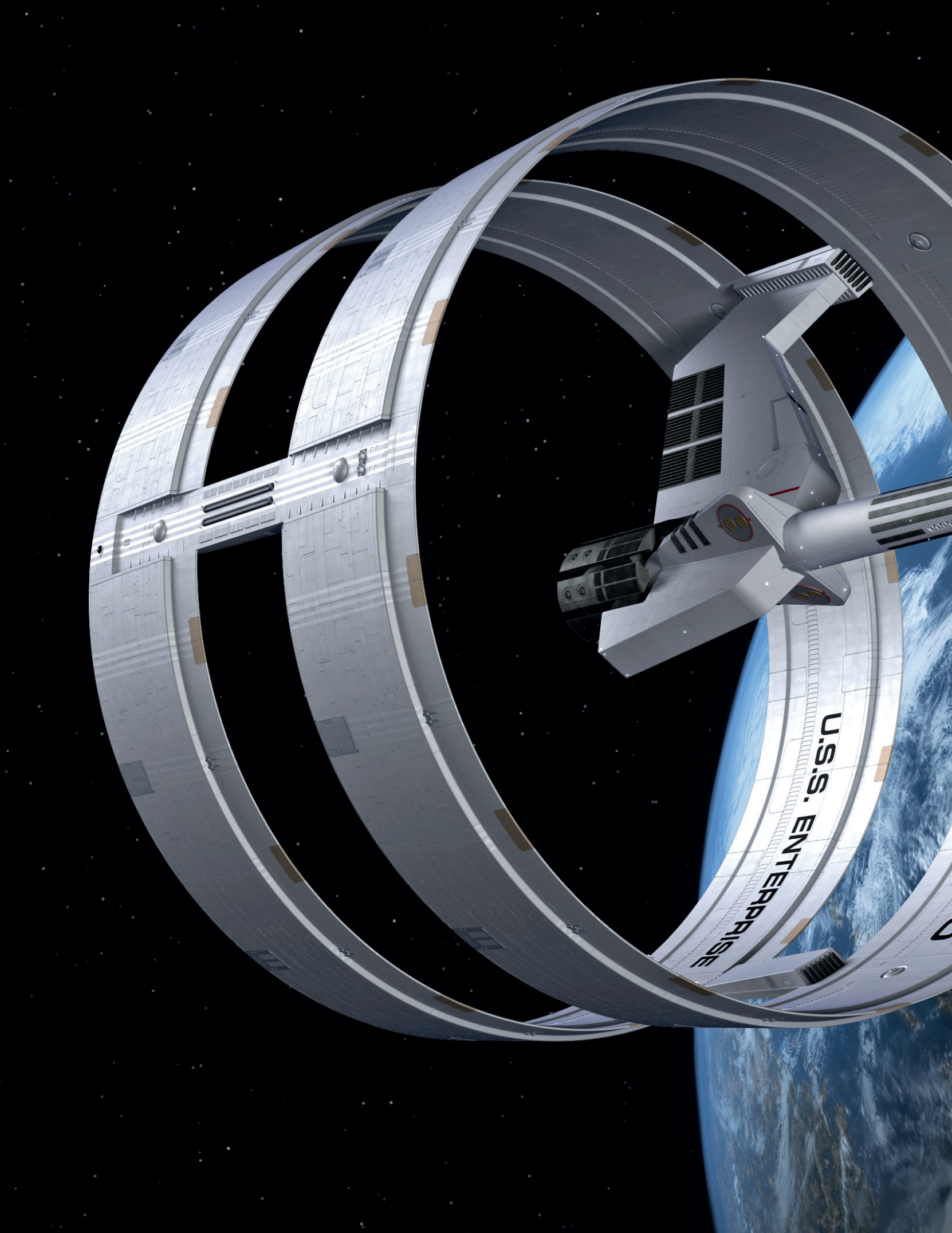

U.S.S. ENTERPRISE



U.S.S. ENTERPRISE XCV-330

Sometime in the 22nd century Starfleet launched the first *U.S.S. Enterprise*.

We know next to nothing about the first spaceship to bear the name *U.S.S. Enterprise*. We know it was launched before 2143, that it had an unusual ring-shaped design and the registry XCV-330. Because of the date, it must have been an Earth rather than a Federation ship. Years later it would be included in a display showing the history of ships that had the name *Enterprise*, but the rest is a mystery...

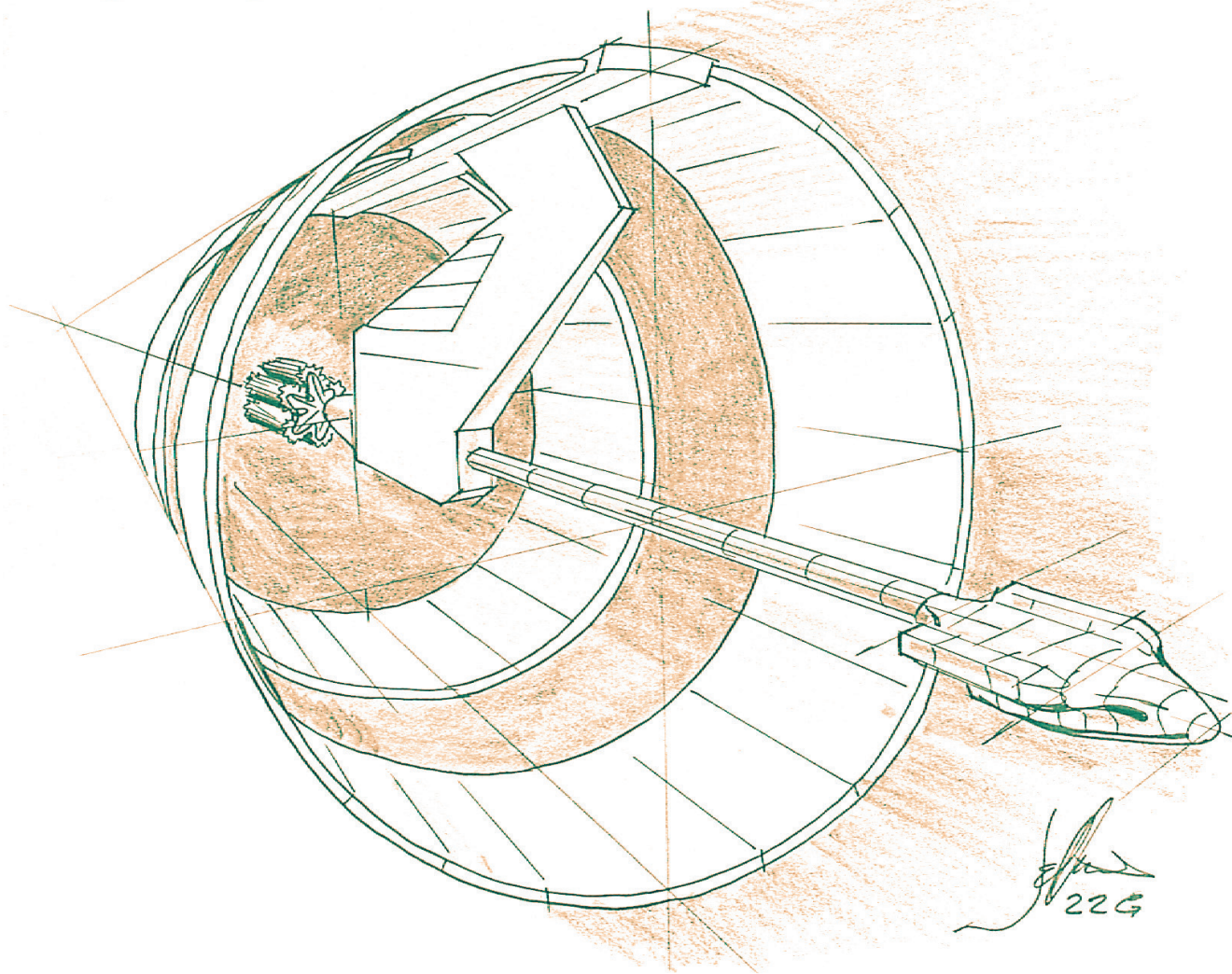

HISTORY OF THE RING SHIP

The most obscure of *Enterprises* has its origins in 1964, and has been sneaking on to the screen ever since.

With *V'ger* hours from Earth, Decker is desperately trying to awaken Ilia's memories in the probe that has taken on her form. As they walk through the *Enterprise's* recreation deck, they pass a series of artworks, "All those vessels were called *Enterprise*" he tells her. The first three vessels would be familiar to anyone: a sailing ship, an aircraft carrier, and a space

shuttle. The fifth vessel is Kirk's ship from the television series, but the fourth vessel is a mysterious ship with a long spar attached to a ring.

You couldn't see it clearly on screen, but the artwork identifies this ship as the *U.S.S. Enterprise XCV-330*, and, since the pictures were arranged chronologically, we can assume that it was in service some time between 1980 and 2271.

▲ The ring ship was originally one of Matt Jefferies' rejected designs for the *Enterprise* - one of dozens of sketches he produced in 1964, as he looked for a design direction for Roddenberry's ship.

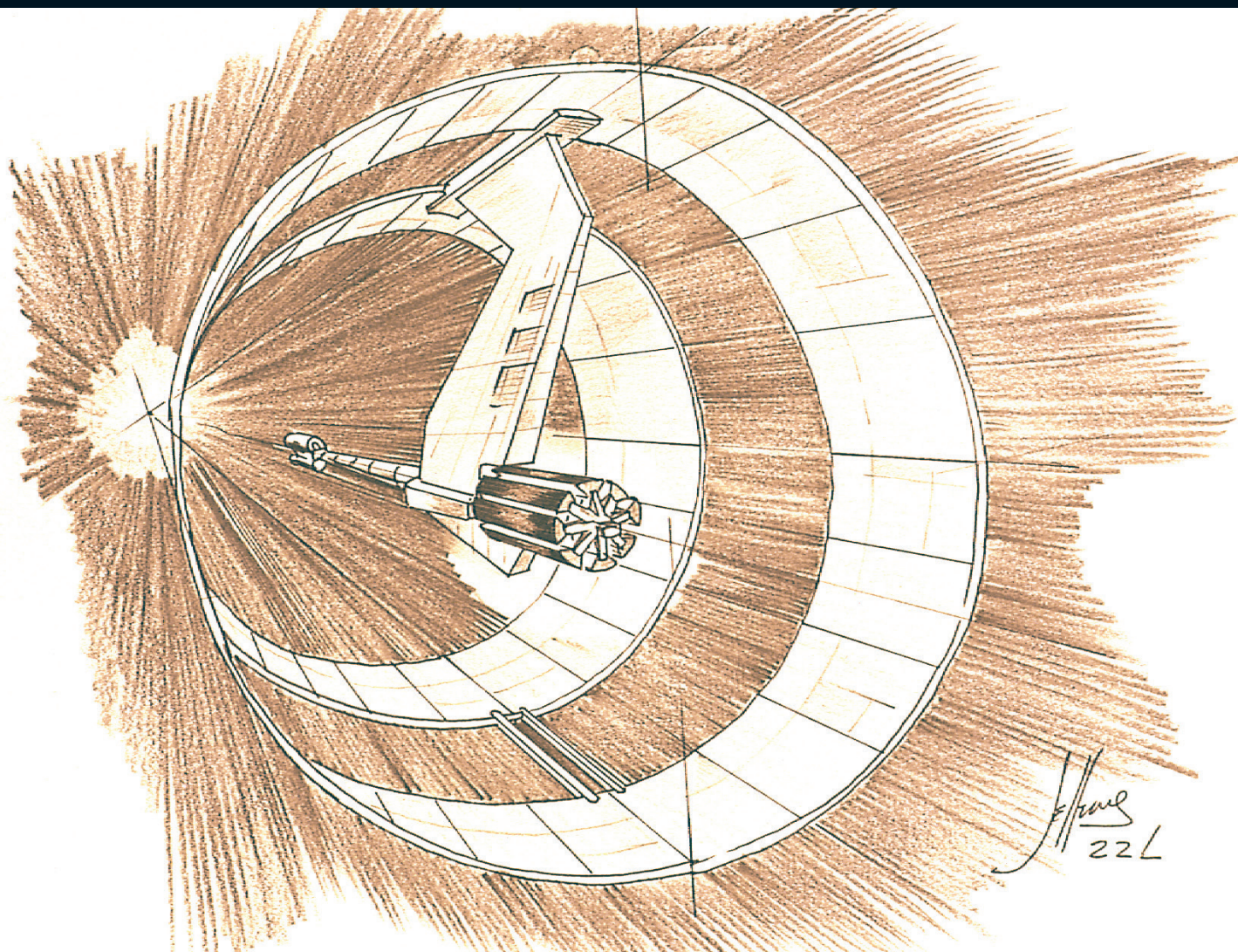

▲► Jefferies spent time on this particular design, producing several drawings showing it from different angles. One of which provided the basis for the painting on the *Enterprise's* rec deck.

The 'ring ship,' as it is known, has never actually appeared on screen, but even in 1979 it would have been familiar to hardcore *STAR TREK* fans. The painting was based on one of Matt Jefferies' rejected designs for the *Enterprise*. When Roddenberry had first approached Jefferies in 1964, he had told him that he didn't want the *Enterprise* to look like a conventional spaceship. Jefferies had a few ideas, one of the most important of which was that because of the vast power involved, the engines should be kept away from the living quarters on the ship. One of the designs he spent the most time on had the engines in a ring that was connected to a spar that would have housed the crew.





▲ The ring ship makes its first and most famous appearance on the rec deck, when Decker is giving the Ilia probe a tour of the *Enterprise*.

Jefferies produced a series of drawings showing the design from different angles before moving on to other approaches. Years later he told Mike and Denise Okuda and Doug Drexler that he had rejected the design because the model would have been too spindly to survive the rigors of filming.

DESIGN RESURRECTION

Jefferies would return to the concept years later, when he was asked to design a spaceship for a prospective Roddenberry TV series called *Starship*. At this point Roddenberry's merchandising company, Lincoln Enterprises, offered fans the opportunity to buy a full-color poster based on Jefferies' design and blueprints of the ship. "Gene Roddenberry's imagination brings you *Starship*. The vessel of the future as only he could picture it," the Lincoln Enterprise's catalog proclaimed. "This could be the forerunner of a new TV series, a starship operated by an enormous computer which is a lifeform itself. Each human on board is a genius, a highly trained science specialist, part of a team of galactic troubleshooters. A brand-new concept in future space travel. We also have three different views of the Metatransit system, side elevations of the systems analysis unit, and the

Metafliter section of the starship. Imagine yourself on a mission in space aboard this luxury cruiser. You'll be spellbound!"

When the art department was tasked with creating the display in the rec deck, Rick Sternbach was called into Roddenberry's office. He remembers that Roddenberry handed him Jefferies' design and asked him to make it one of the drawings that was shown on the wall. Sternbach gave the ship the registry XCV-330, an evolution of NASA's designation for the *Enterprise* space shuttle, which has the registry OV-101. Apart from producing the painting, he thought no more of it, and says he has no idea of how the ship fits into the history of spaceflight.

In 1980 Susan Sackett and Gene Roddenberry published *The Making of STAR TREK: THE MOTION PICTURE*, which briefly mentions the ring ship in a passage that refers to the display on the rec deck: "Since this was 23rd-century artwork, the fourth illustration is of the very first starship *U.S.S. Enterprise* (never seen on television but according to Gene Roddenberry, who supplied the sketch, it is a forerunner of the vessel we all know)."

The ring ship was also referred to in two other licensed books that were published to tie in with the release of *TMP*. Today, neither book is

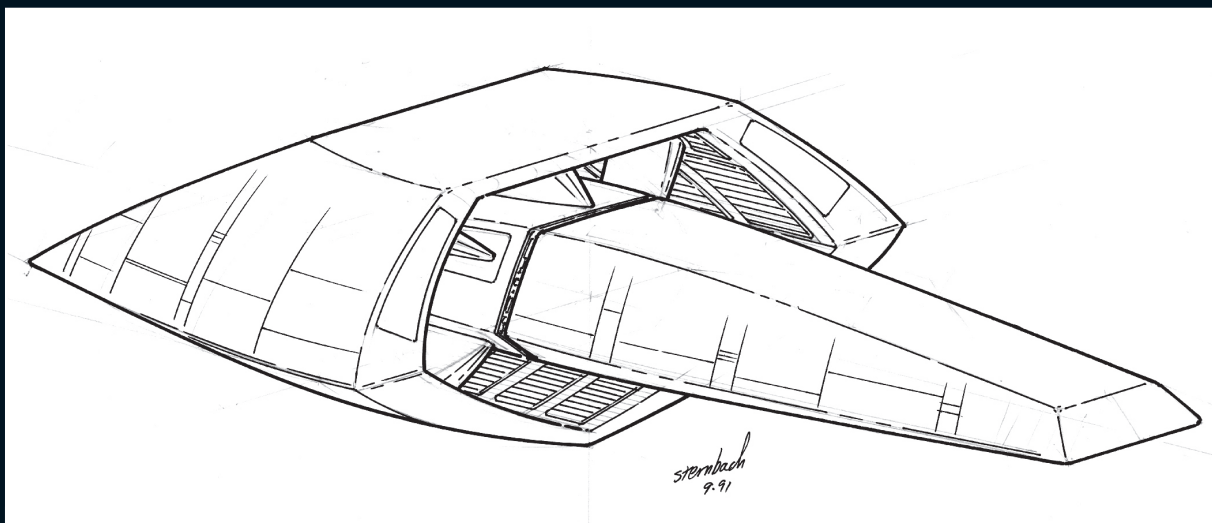

◀ Rick Sternbach's design for the Vulcan ships in *Unification* was inspired by Jefferies' original ring concepts and established a design approach that would be used for Vulcan ships in the future.



◀ When Doug Drexler was designing the NX-01, he put forward several designs that incorporated the rings, suggesting that this was a technology that pre-dated the arrangement of nacelles, saucer and engineering section that we are familiar with.

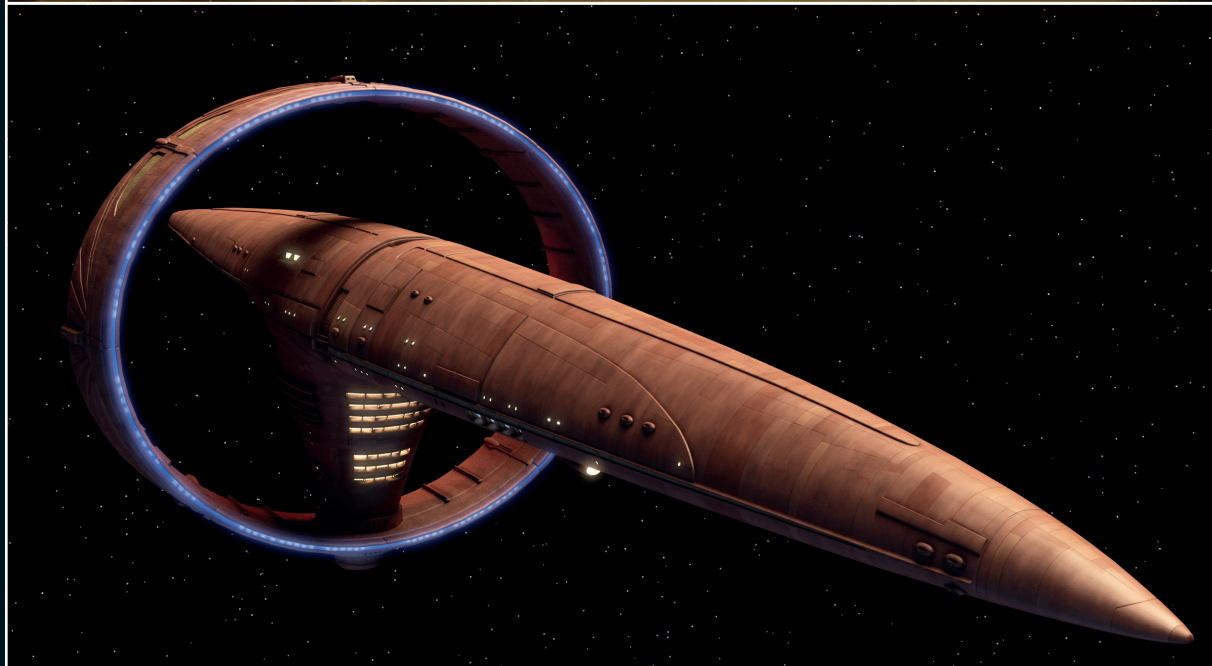

◀ Drexler took all the important elements of the ring ship and used them as the basis for the first new Vulcan ship that we saw on *ENTERPRISE*.

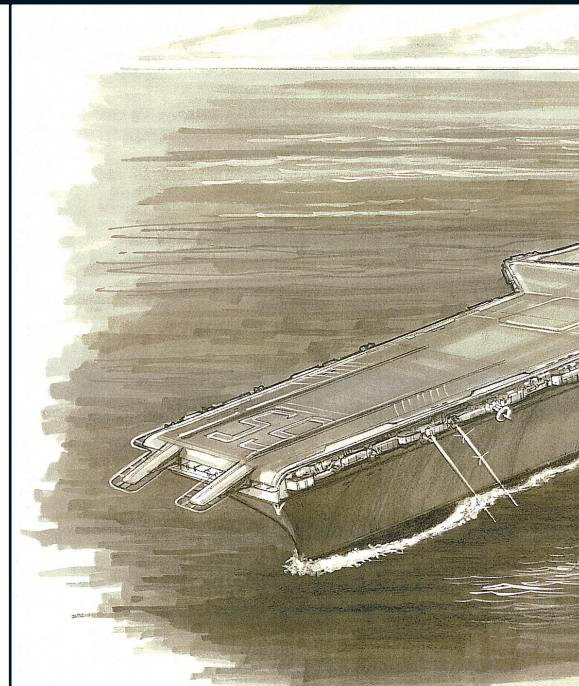
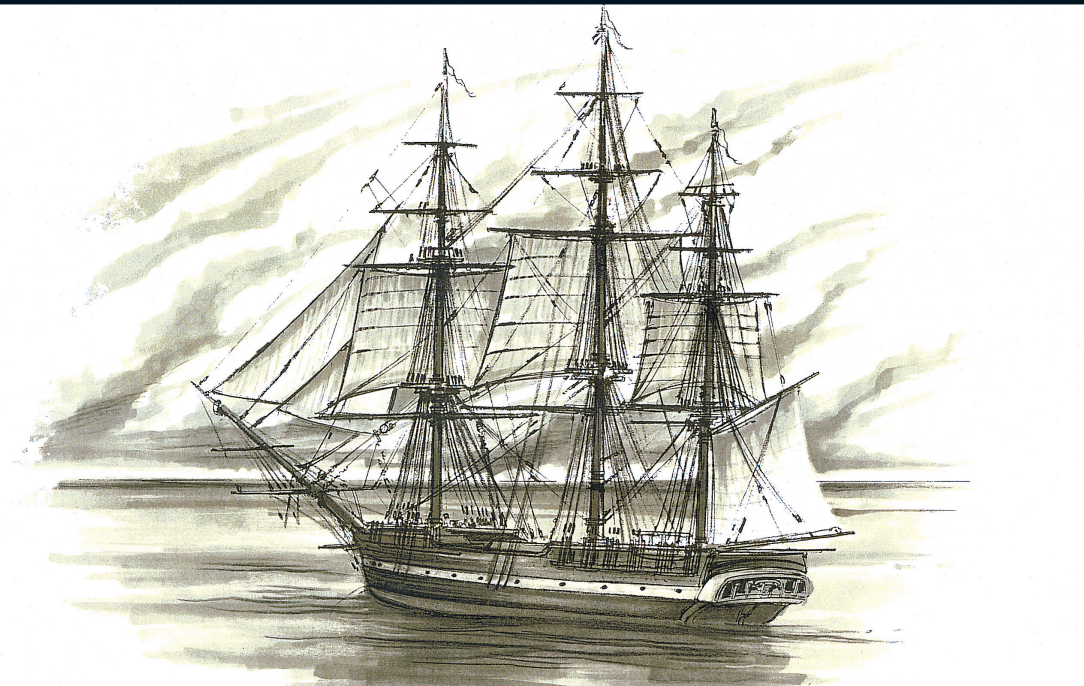

▲► Ironically, the one place the ring ship has never turned up is in displays showing the *Enterprise's* history. It isn't among the artworks that John Eaves produced for Archer's quarters or in any of the displays that appeared on the *Enterprise-D* or *Enterprise-E*.

considered canon since they contradict many of the facts established on screen, and, in the case of the ring ship, one another.

STAR TREK Maps identifies the ring ship as a starliner that was one of several interstellar probes that were launched in the 2050s, whereas the *STAR TREK Spaceflight Chronology* says that it was a Declaration class interstellar liner that was launched in 2123.

The Okudas included the ring ship in their reference book the *STAR TREK Encyclopedia*, where they identified it as the *S.S. Enterprise*. But otherwise the *Enterprise XCV-330* was effectively forgotten for decades until members of later *STAR TREK* art departments resurrected it.

When Sternbach was designing the Vulcan cruisers for the *TNG* story *Unification*, he deliberately put the engines in a hoop as a tribute to Jefferies' concept art.

MISSED APPEARANCES

Okuda remembers that when the art department was working on *STAR TREK: FIRST CONTACT* they made a small model of the XCV-330 which they sprayed gold with the intention of adding to the display in the *Enterprise-E's* conference lounge. However, when it came to filming, it was decided not to include it.

Soon afterwards, Rick Berman and Brannon Braga started work on *ENTERPRISE*, and, since the

series would feature an *Enterprise* that was a precursor of Kirk's ship, Okuda and Drexler raised the possibility of using the XCV-330 for Archer's ship. The producers felt this was too radical a departure, but Drexler continued to incorporate elements of the ring ship into the designs he was submitting for the new *Enterprise*. Again they were rejected and the producers finally settled on the familiar version of the *Enterprise NX-01*.

SUBTLE REFERENCES

But the story of the XCV-330 was not over. When Drexler was asked to design the first new Vulcan ship, he took the fundamental elements of Jefferies' design and reconfigured them to create the *Surak*. When you look at his Vulcan ship with this in mind it's easy to see all the aspects of the ring ship.

In *ENTERPRISE's* second season, the writers developed a story that was set on Earth during the development of the Warp 5 engine. Okuda took the opportunity to slip the ring ship into the story. In *First Flight*, Archer is one of a several test pilots who visit the 602 bar. On the wall there are various badges for space missions that date all the way back to the Apollo program. It can't be seen on screen, but one of the mission patches, designed by Okuda, shows the ring ship and identifies it as being the *Enterprise XCV-330*. Okuda deliberately left the U.S.S. designation off, because it causes a

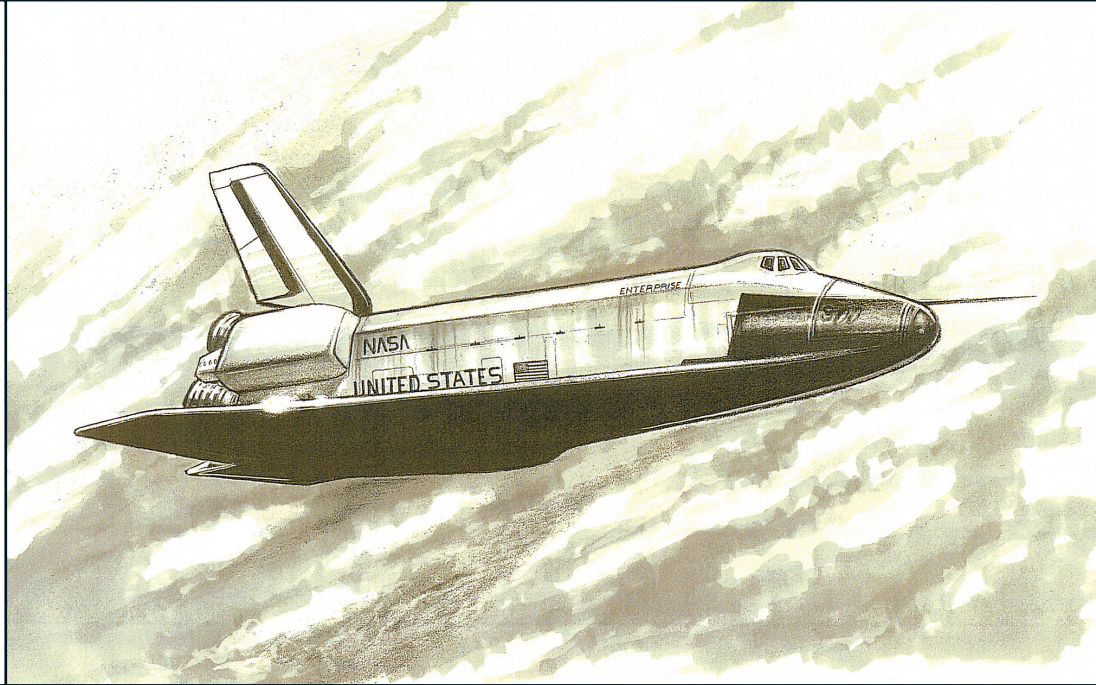
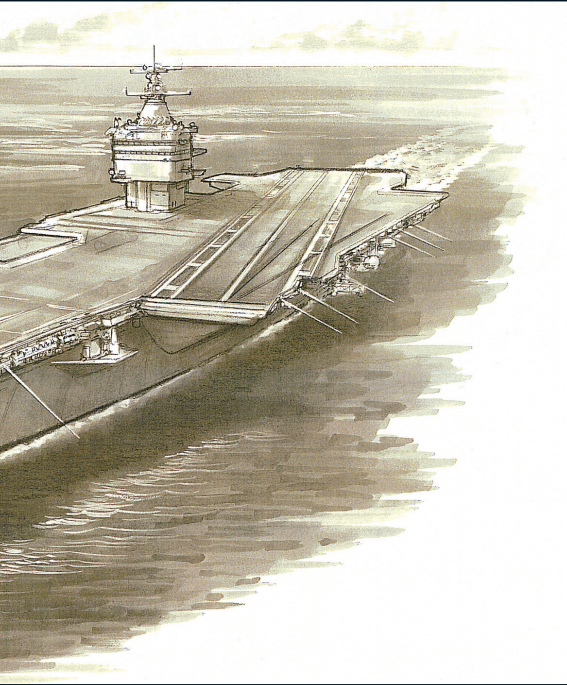

problem with continuity: *ENTERPRISE* established that the prefix was used for Federation rather than Earth ships, and the story was set years before the Federation was formed. Okuda also created a “quick and dirty” painting showing the ring ship, which was hung over the bar.

Okuda and Drexler theorized that the ring ship was an early warp ship that used similar

technology to the Vulcans. The engine ring had been abandoned in favor of a return to Cochrane’s familiar warp nacelles, and this eventually led to the design of the *Enterprise* NX-01.

Okuda is fairly certain that both the painting and the gold model that was made for *FIRST CONTACT* were later reappropriated to decorate

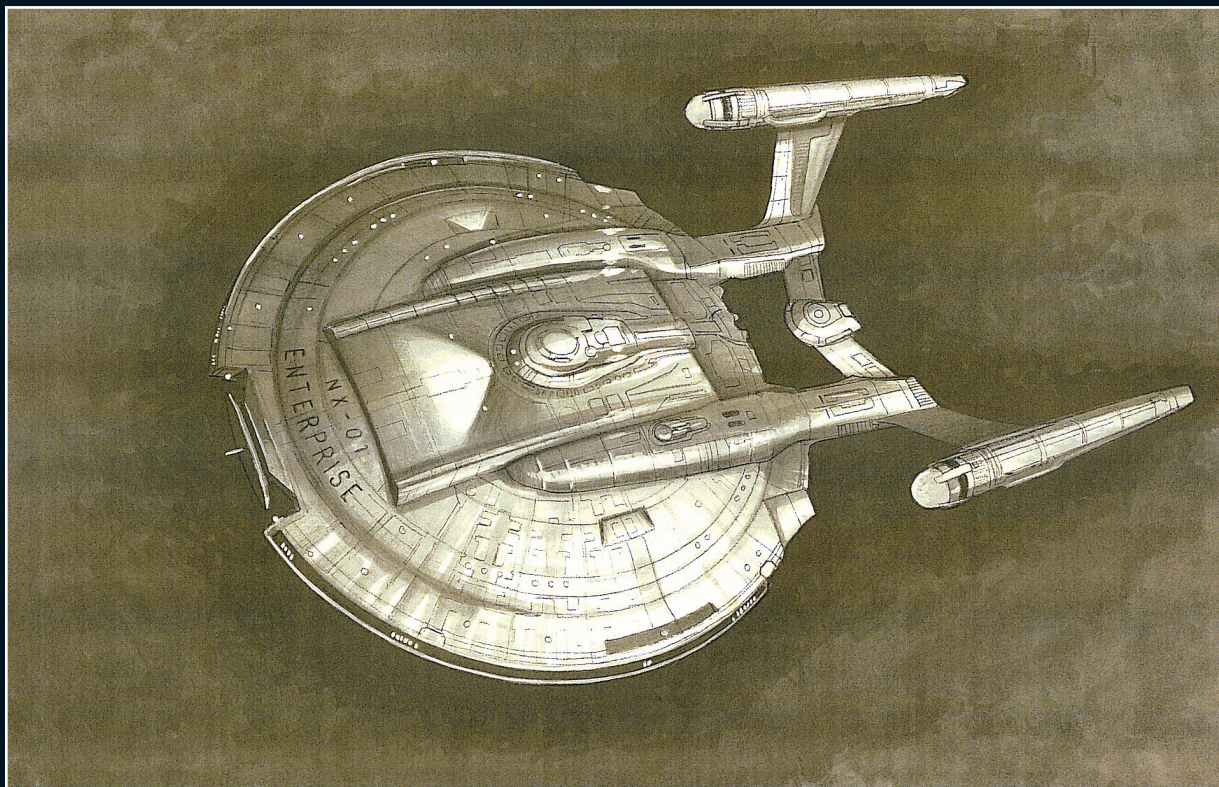

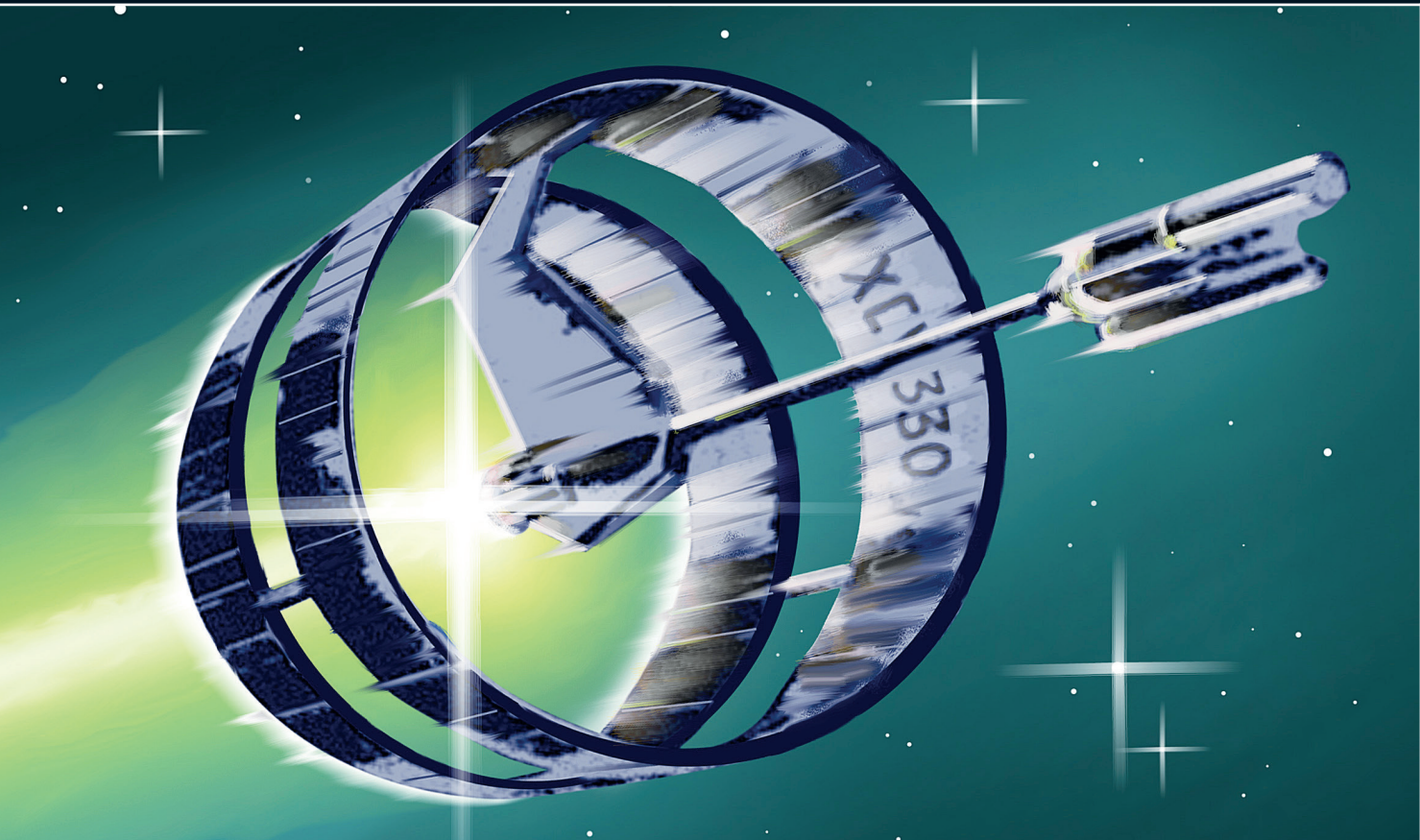

▲ Mike Okuda produced this painting of the ring ship that appeared in the 602 bar, where *STAR TREK*'s equivalent of astronauts congregated and in Admiral Forrest's office.

Admiral Forrest's office. The model was never seen on screen, but the painting could be clearly seen in the episode *Home*.

NEW LIFE

The ring ship made its next appearance in the 2011 *Ships of the Line Calendar*, where it was given the center spread. The artwork was created by CG-modeller Mark Rademaker, who based his model on Sternbach's original painting, but

inevitably had to fill in a lot of details. Rademaker worked with Andrew Probert who had designed many of the ships that had appeared in *STAR TREK: THE MOTION PICTURE*. Rademaker would produce renders, which Probert would then sketch on top of, making suggestions about what the finished ship should look like. The final version included transparent areas at the front and changed the size and position of the name and the registry.

The calendar provided some new information about the ring ship, and the text with the image reads: "The XCV *ENTERPRISE* was a radical reinvention of warp technology based on Vulcan design principles. It proved to be 17% more efficient than Vulcan ships, but had trouble turning at high warp speed, thus making it impractical for exploration where sudden course changes would have to be made. It was considered a technological dead-end in Earth Starship Design."

Rademaker then handed the model on to QMx, who were considering making a version of it, but as far as he knew the project was abandoned. The story of the ring ship still wasn't over.

The art department for the movie *STAR TREK INTO DARKNESS* wanted to decorate Admiral

► Okuda also produced a mission patch for the *Enterprise* XCV-330 that was used in the 602 bar.



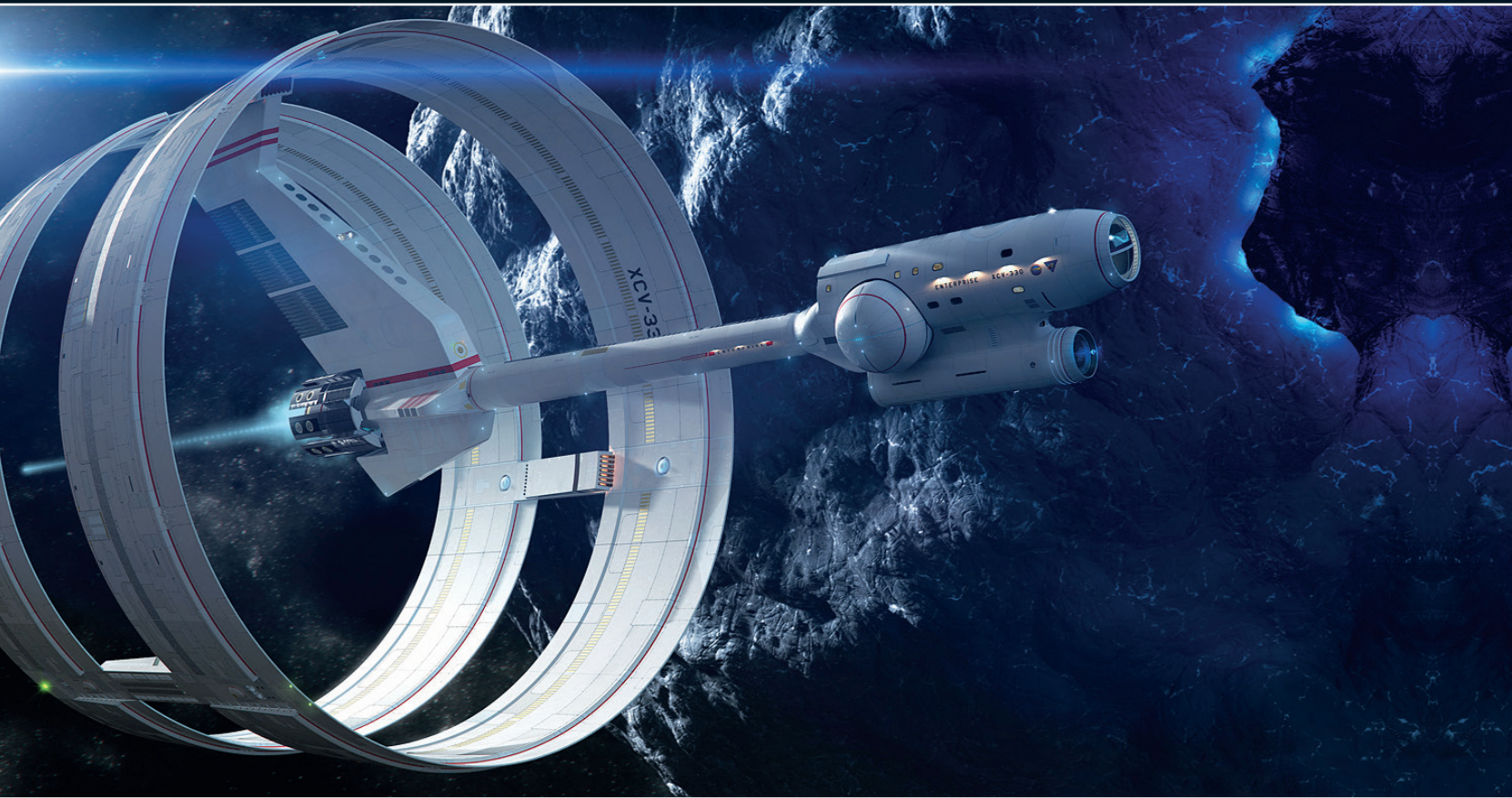

Marcus's office with a display of 14 model ships showing the evolution of spaceflight from the Wright Brothers to the *U.S.S. Vengeance*. QMx were tasked with creating the models which included a version of the *U.S.S. Enterprise XCV-330*. They based their model on Rademaker's CG version, and, according to Rademaker built the model in two weeks.

The accelerated schedule meant that the first

time Rademaker learned about the model was when he saw it on screen. QMx later released a limited edition replica of the model, which they took the opportunity to upgrade. That was the last appearance of the ring ship to date but after nearly 40 years, it has proved remarkably resilient, and as *STAR TREK: DISCOVERY* demonstrates, there are always new parts of the *STAR TREK* timeline that have yet to be explored.

▲ The *Enterprise XCV-330* appeared in the 2011 *Ships of the Line Calendar*, and the CG model created for that was used as the basis for a physical model that could be seen in Admiral Marcus's office in *STAR TREK INTO DARKNESS*.





THE MOTION PICTURE'S LOST ALIENS

The ring ship wasn't the only obscure element introduced in *TMP* – there were also several alien races that have been largely forgotten.

▲ An Arcturian clone having his head fitted. On the table to the left, you can see masks for several other species, including Saurians and Betelgeusians.

Everything in *STAR TREK: THE MOTION PICTURE* was more ambitious than it had been in the television series. One of Roddenberry's goals was to show many more alien species. So the makeup department, led by Fred Phillips, and the costume department, led by Robert Fletcher, worked together to create several new races.

Rather than simply designing something that looked cool, Fletcher developed back-stories for the new species, which were revealed in the book *The Making of STAR TREK: THE MOTION PICTURE*, which was written by Susan Sackett, with Roddenberry's input and approval. Fletcher also expanded on some of the back-stories in a two-part interview about *TMP*'s costumes that

was published in the magazine *Fantastic Films*.

The aliens were featured in the scenes at Starfleet Headquarters and when Kirk briefs his crew. However, when it came to filming there was some concern that the makeup wouldn't stand up to close scrutiny so most of them were put in the background and were barely seen. After seeing the finished film, Roddenberry said he wished they had been more adventurous and put them up front. Some of the aliens were made into toys by the company MEGO, but otherwise they were almost all forgotten and never reappeared on screen. Fletcher's back-stories can't be considered, but they provide a fascinating insight into the thinking of the time.

AAAMAZZARITES

The Aamazzarites are described as “Therbians,” and according to Fletcher’s notes, they made their clothing from their own mouths, “like bees making hives.” In fact, the Aamazzarites produced everything that was used in their culture by using the biochemistry of their own bodies, including furniture. The costumes that Fletcher made were modelled in clay and then cast in foam rubber.



RHAANDARITES

These simple, gregarious people were from the Rhaandaran system. They were extremely long-lived, and didn’t reach adulthood until they were 150 years old. They could grow to eight or nine feet tall, though they might not reach this height until they were 200 years old. The women were as large and strong as the men. A member of this species could be seen on the bridge.



ARCTURIANS

The Arcturians were a race of clones who were noted for their military achievements, and provided the Federation with infantry. They came from a massive planet, with a population of 100 billion. Because of their ability to clone themselves they could produce an army of 20 billion overnight. Because they were cloned the only way to tell them apart was to look at the details of their costumes, which were color-coded to show regiment and rank. *THE ORIGINAL SERIES* refers to Arcturians: in *The Conscience of the King*, Kirk remarks that Karidian puts on an Arcturian version of *Macbeth*.



ZARANITES

The Zaranites could not breathe oxygen, so when they were on Earth onboard the *Enterprise*, they needed special breathing apparatus, which was connected to a pack they carried on their backs which generated fluorine gas. Although they always wore the breathing apparatus on screen, Phillips did design the lower part of their faces (above). Fletcher made their costumes from "old suedes left over from *The Ten Commandments*." Fletcher says that their jewelry was made from the horns of the Berbbotjahaa.



SAURIANS

Fletcher's Saurians were a lizard people, who, he says, made excellent space officers. They had a complicated language of their own, but had also learned to speak "in Earth tongue." Fletcher says that they had four hearts, which gave them enormous strength, and could breathe a number of different gases, and these qualities made them excellent explorers. Presumably they were responsible for the famous Saurian brandy, which is frequently referred to in all the incarnations of *STAR TREK*.





K'NORMIANS

The K'normians, from the planet K'norm, are described as being very similar to humans but with additional brain structures that performed "functions that we aren't capable of, mainly for long-distance communications." Fletcher also says that the K'normians had an eighth sense that could deal with the space and time dimension. The K'normians get a brief mention in *STAR TREK INTO DARKNESS* when Kirk, Spock and Uhura use a K'normian ship Kirk confiscated from Harry Mudd to fly down to the surface of Qo'nos.



SHAMIN PRIEST

These masked people were from O'Ryan's planet, which was discovered by Paddy O'Ryan in the 22nd century. Their costumes were made of fabric and a liquid plastic that turned into a different material when it solidified, a process that Fletcher developed for the movie. The undergarment was a special material that was woven on a hand loom and was originally intended for Spock's ceremonial robes. Fletcher told the magazine *Fantastic Films* that the Shamin were a relatively primitive people who were at an early stage of social and technological development.

MEGARITES

The Megarites came from a planet that was mostly made of jade. They normally lived underwater, but Federation scientists had found a way of letting them leave by using special injections. Their clothing was designed to look as if it was made from various sea animals. The Megarites' bodies were like rhino hide. They had four lips, and used a straining method similar to the baleen of whales to feed. They were a very poetic people, who used musical poems and songlike sounds to communicate.



RIGELLIANS

According to Fletcher, the Rigellians were descended from a race of saber-toothed turtles, who had learned to walk upright. They only had one sex and reproduced by laying eggs. They ranged in height from five foot nine to seven foot tall. The "real power" lay with the attendants who served the lords, fed and cared for them. They wore ceremonial armor, which consisted of a helmet and a breastplate. This replaced their shells, which they had lost over years of evolution. The armor was sculpted in the Paramount studio craft shop, and were made of chrome-plated fiberglass. The rest of their costumes were made of draped wool. The hands and feet were sculpted from rubber. A very different looking race also called the Rigellians appeared in several episodes of *ENTERPRISE*.

KAZARITES

The Kazarites were telepathic and telekinetic shepherds, who came from a technologically advanced planet where they still raised "great herds of beasts." They were extremely powerful - they could communicate telepathically with all animals on all planets, and could transport themselves by the power of thought. Their spacecraft were also powered by thought. They were the ecologists of the Federation and some of them had relocated to Earth, where they helped to look after animals, fish and bird life. The small bags around their necks were used to carry food pellets, which they mixed with water to make a yeastlike substance.



BETELGEUSIANS

The Betelgeusians were from a planet orbiting the famous star. They were humanoid but evolved from giant "leopardlike birds." As a result they had characteristics that we might associate with eagles and leopards. They had claw and bone structures that were like a condor's, but walked upright. According to *The Making of STAR TREK: THE MOTION PICTURE*, they were all over seven feet tall, the costumes they wore were found in the Paramount stores and at least 40 years old, and their jewelry was made of fabric but was electro-plated. Costume department photography identifies two different Betelgeusians: an ambassador, who was dressed in multi-colored robes, and an attendant, who was dressed in gold.

STAR TREK™

